

DH1~DH2=13499 (±20)

Coordinates

Mark	X	Y	R
GM	0	0	—
DH1	-6850	-1200	—
DH2	6620	-2080	—
a1	-6062	-3648	300
a2	-5872	-4111	200
a3	-4850	-4915	200
a4	-4356	-4991	300
a5	3166	-5581	300
a6	3665	-5583	200
a7	4800	-4948	200
a8	5060	-4521	300
f1	4684	5943	1300
f2	-6086	4956	1300

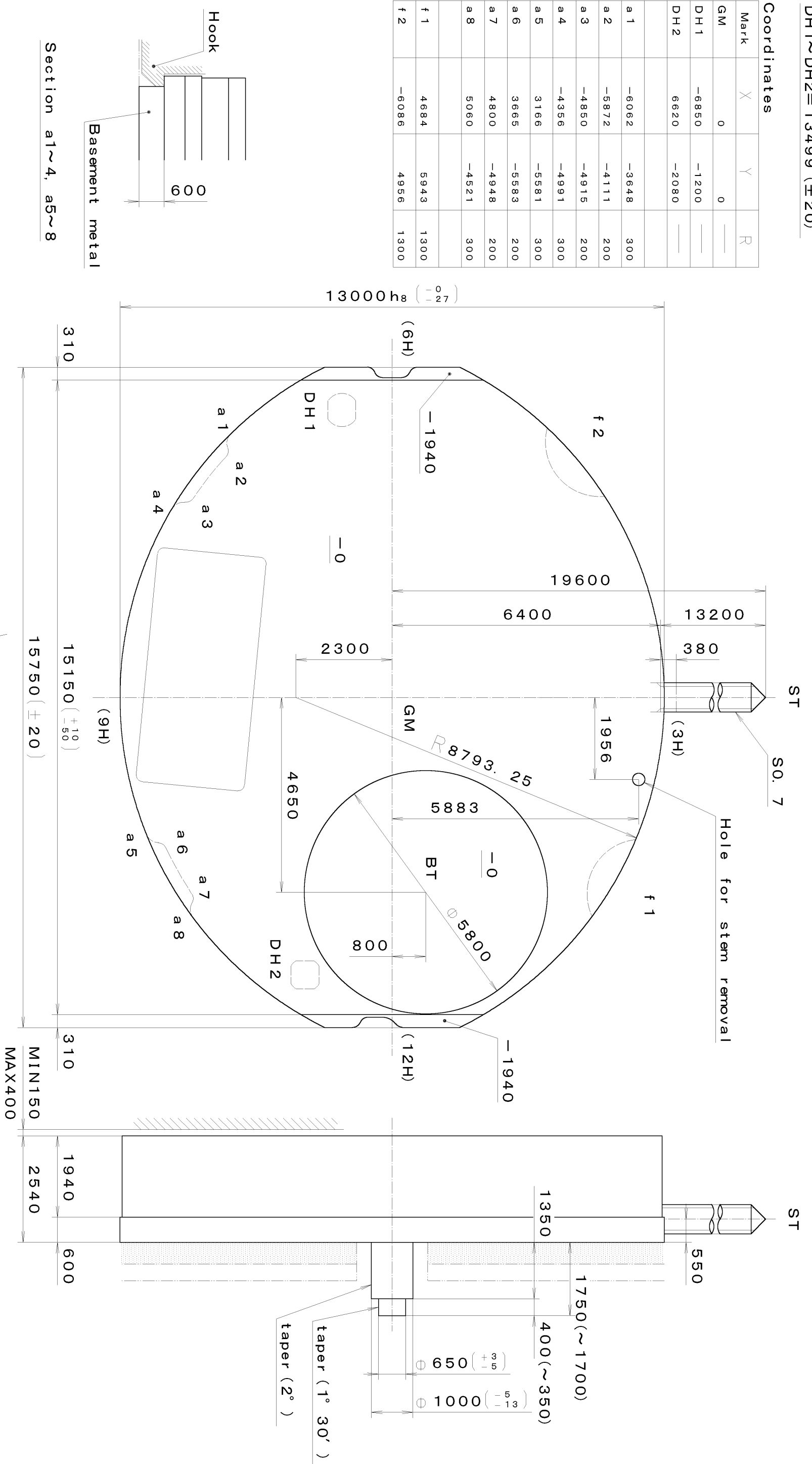

Section a1~4, a5~8

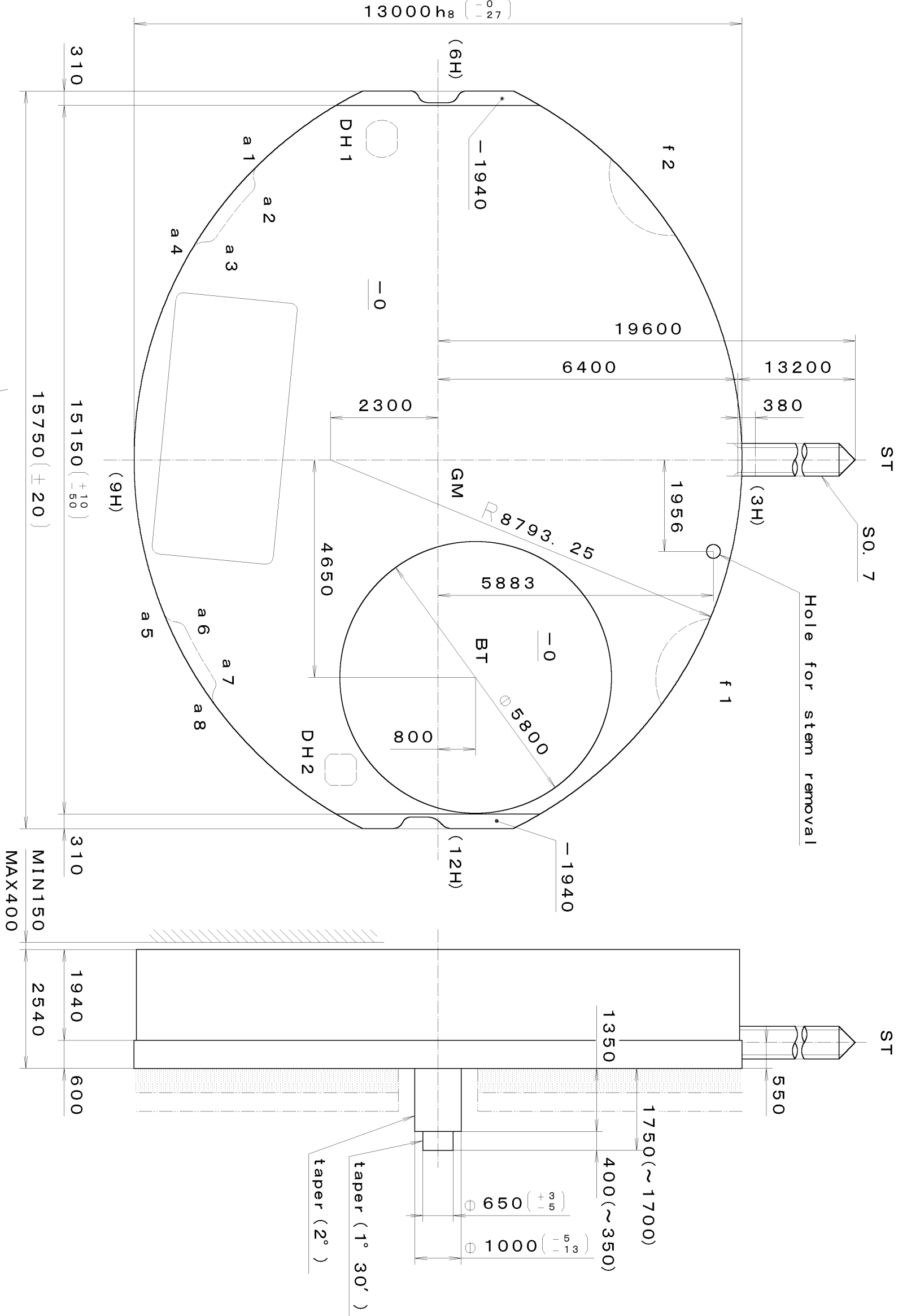
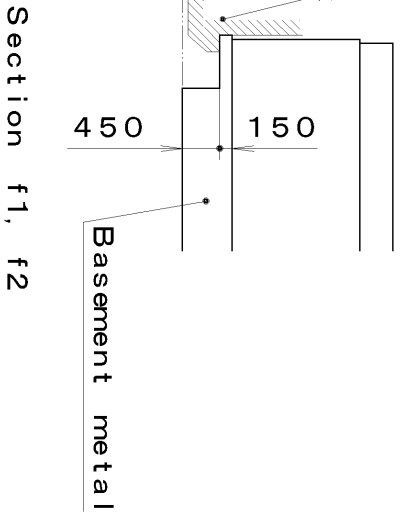
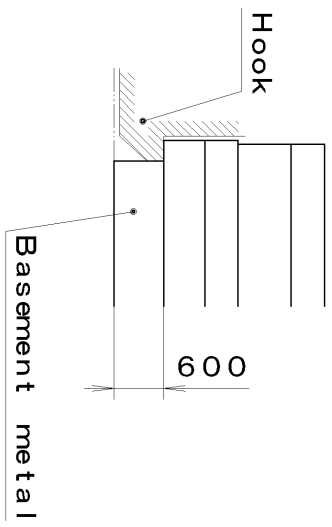

Quantity	Unit	1/1000 mm	Cal. No. : 5Y26
△	Scale	11:1	Parts:
△	Date		
△	Drawn		
△	Checked	T. Hiruta	Name: Frame for Case
△	Approved		Drawing No. : 5Y26C000
Material			
Heat Treatment			
Hardness			
Plating			
General Tolerances			
Dimensions			
Angles			

This drawing is provisional and subject to our reconfirmation and/or revision without notice.

*** T I P W (01) *** (2100 1121) 00-06-22

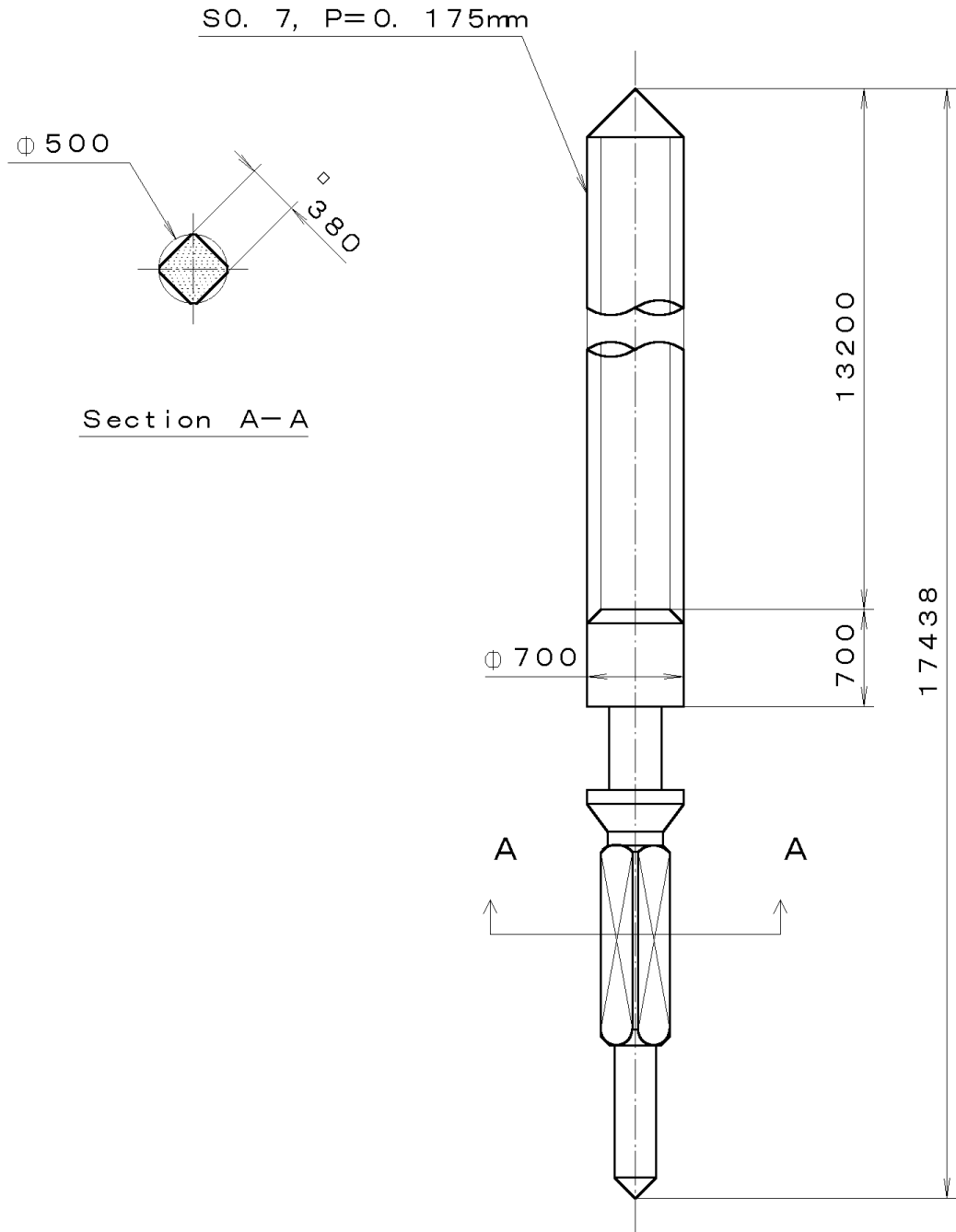

7			Quantity		Cal. No. :
6			Unit	1/1000 mm	Parts:
5			Scale	20:1	
4			Date		065-403
3			Drawn		
2			Checked	T. Hiruta	Name:
1			Approved		SETTING STEM
Material					Drawing No. : 4030S000
Heat Treatment			General Tolerances		
Hardness			Dimensions		
Plating			Angles		